

11 10 9 8 7 6 5 4 3 2 1

POLE	HP	kW	Hz	VOLT	r/min(RPM)	INS	RATING	DIMENSION IN	APPROX WEIGHT	BEARINGS
4	125	93.3	60	230/460	1800	F	CONT.	INCHS	1800 LBS.	DE: 6318 NDE: 6316

G
F
E
D
C
B
A
e

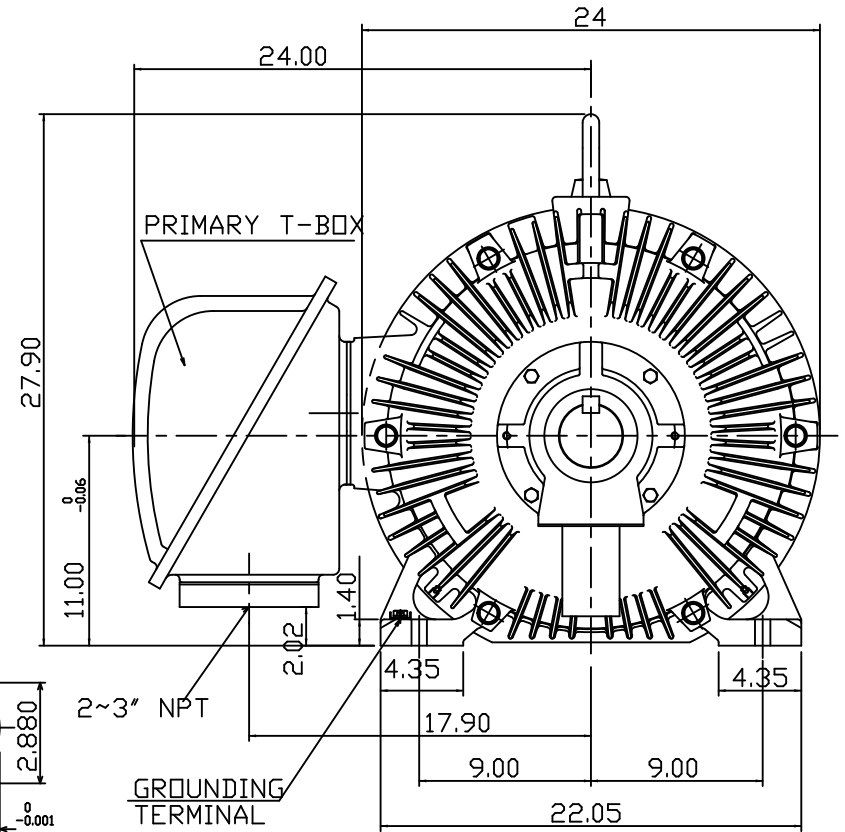
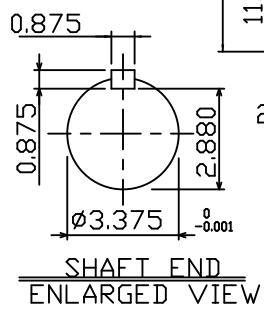
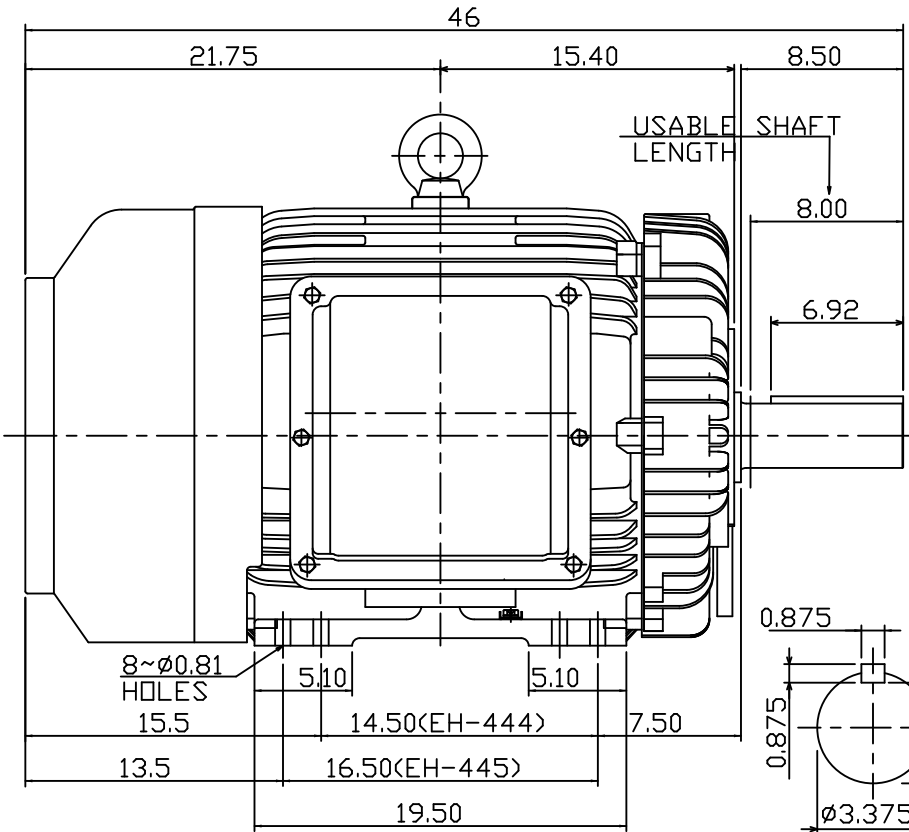

NOTE:

1. DIMENSIONS IN INCHES
2. FRAME NO. 445T
3. F CLASS INSULATION, S.F.1.15
4. FOR BELT SERVICE
5. ENCLOSURE: IP55
6. WITH THERMISTOR: PTC 140°C 3PCS
7. SHAFT MATERIAL: SCM440 Q&T (AISI 4140 EQUIV)
8. CORROSION PROOF

OUTLINE DIMENSIONS			
3-PHASE INDUCTION MOTOR			
MOTOR TYPE	AEHHGD	FRAME NO.	445T
CATALOG NO.	CDP1254	DATE	02-01-2018
TEC Westinghouse			DWG NO. 31057G021300
DWG.	C.COOK	02-01-18	

11 10 9 8 7 6 5 4 3 2 1

第三角法